



VW GOLF VII, GOLF VII Variant, PASSAT (3G2), PASSAT Variant (3G5), PASSAT ALLTRACK (3G5)



WARNING

Health risk!

Inhalation of brake dusts may result in serious damage to the respiratory organs!

Do not clean brake components with compressed air.

Use brake cleaner fluid.

NOTE

Move back brake piston using the diagnostic unit prior to any work on the brake system.

Note position of EOBD connection.

The illustrations of these installation instructions are exemplary and are only intended for better understanding.

General reference notes

Suitable roller brake tester needed for permanent all-wheel drive.
Electromechanical parking brake servomotors are located at the rear brake calipers.

The electromechanical parking brake can be actuated with the ignition switched off but it cannot be released.

Electromechanical parking brake switch is located in the center console. **(1)**

(see figure 1)

Figure 1

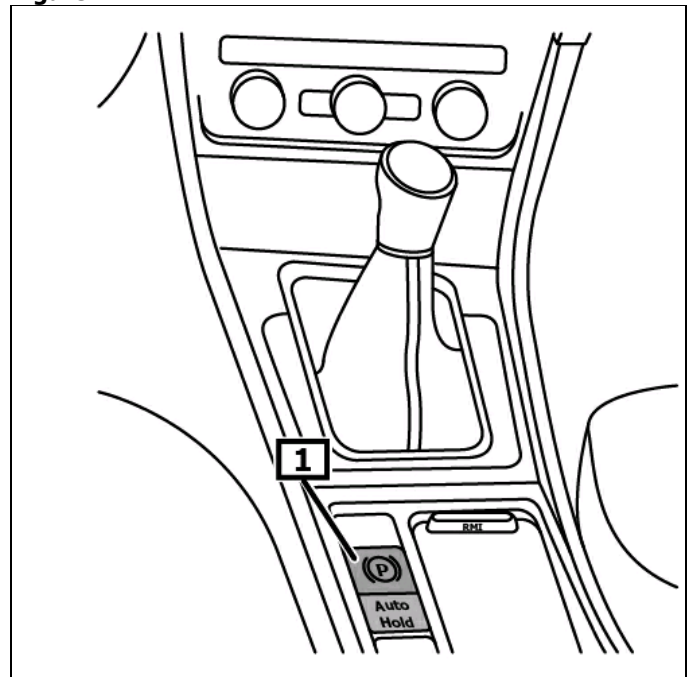

1 Parking brake switch

Display/operation

Engage parking brake

Pull parking brake switch and hold. **(1)**
(see figure 1)

Note: Electromechanical parking brake indicator light must be on in the instrument cluster and in the parking brake switch.

Release parking brake switch. **(1)**
(see figure 1)

Disengaging parking brake with the engine cut:

Switch on ignition.

Press parking brake switch and simultaneously operate brake pedal.

Note: Electromechanical parking brake indicator lights must go out.

Disengaging the parking brake with the engine running:

Press parking brake switch and slightly apply accelerator pedal or brake pedal at the same time.

Note: Electromechanical parking brake indicator lights must go out.

For further details and information, please refer to the operating manual!

Figure 2

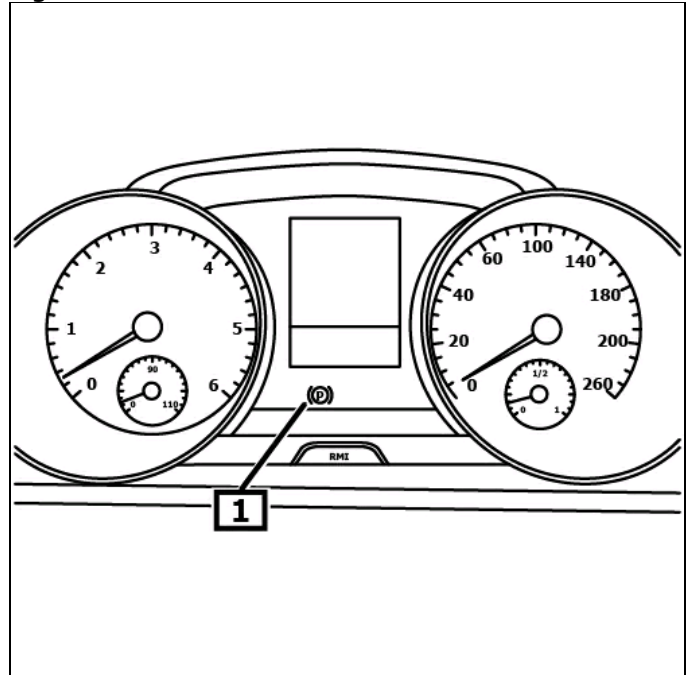

1 Electromechanical parking brake indicator light

Move back brake piston using a diagnostic unit prior to any work on the brake system.

Note position of EOBD connection.

Connect diagnostic unit to diagnostic connection.

Switch on ignition.

Disengage parking brake

Follow the instructions of the diagnostic unit.

After repair work

Follow the instructions of the diagnostic unit.

Carry out basic adjustments using suitable diagnostic unit.

Check fault memory, and delete fault if necessary.

Carry out brake test on test stand.

Note: Suitable roller brake tester needed for permanent all-wheel drive.

The front wheels must be fixed during the test.

Drive the rear vehicle wheels onto the testing stand, leaving the ignition on.

Test mode will be automatically activated when the test speed is higher than 3 km/h.

On the display the yellow, crossed out parking brake symbol will appear.

The parking brake is being closed a bit at every switch actuation.

Parking brake completely engaged after hitting the switch 4 times.

Note: Parking brake released after hitting the switch 5 times.

Required torques

Self-locking screws and nuts must always be replaced.

Servomotor screw(s) (2)	(see figure 3)	
-------------------------	----------------	--

Parking brake emergency unlocking device

Remove:

Switch off ignition.

Secure vehicle against rolling away.

Lift vehicle.

Remove rear wheels.

Keep waiting time of min. 30 s.

Disconnect the electric plug connection(s) on the servomotor.

(1)

Unscrew screw(s). (2)



CAUTION

Servomotor can twist when both screws are screwed out.

Outer limbs can be squashed.

Carefully remove servomotor from brake caliper.

Remove the actuator(s). (3)

(see figure 3)

Figure 3

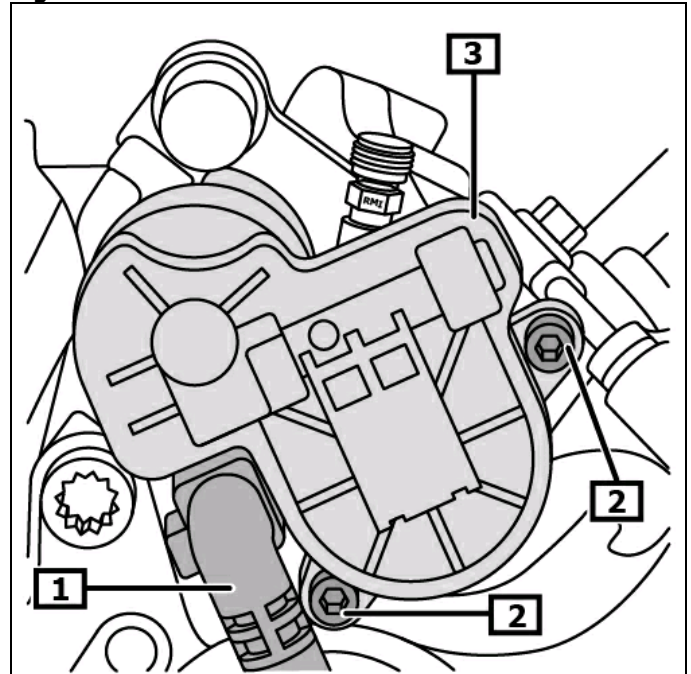

1 Electrical connection(s)

2 Screw(s)

3 Servomotor(s)

Insert adjusting tool(s). (1)

Torx bit (**commercially available**)

Turn back brake piston spindle until brake is free. (2)

(see figure 4)

Figure 4

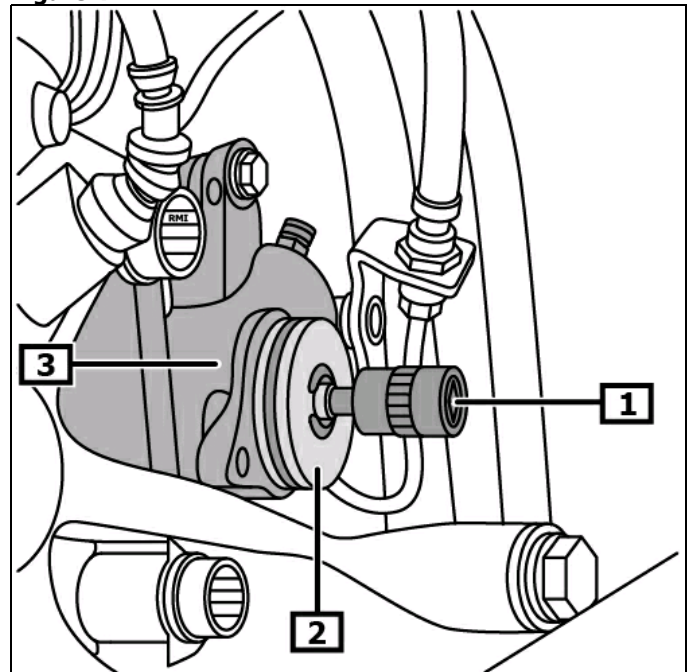

1 Torx bit

2 Brake piston spindle

3 Brake caliper

Install:

Remove the sealing ring(s). **(1)**

Clean sealing ring groove. **Do not damage seal ring groove.**

Clean sealing face(s). **(2)**

Do not damage sealing surface(s).

Replace sealing ring(s). Grease sealing ring(s).

Do not damage or twist sealing ring(s) during installation. (1)

Grease servomotor shaft. **(3)**

(see figure 5)

Carefully place parking brake servomotor at brake caliper. **(3)**

(see figure 3)

Pay attention to correct sealing ring seat! (1)

(see figure 5)

Servomotor must be flush on brake caliper for assembly. Servomotor must not be pulled toward brake caliper using the screws.

Carry out basic adjustments using suitable diagnostic unit.

Figure 5

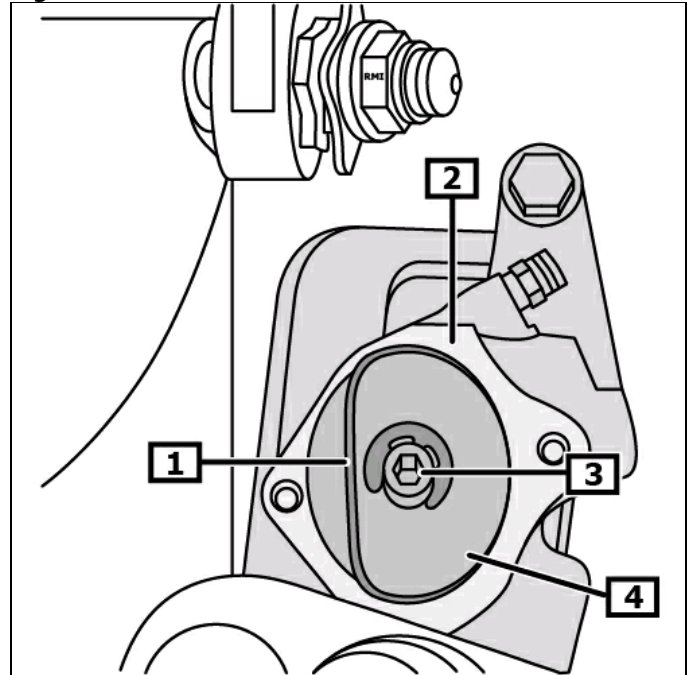

1 Sealing ring(s)

2 Sealing surface(s)

3 Servomotor shaft

4 Brake piston spindle