



PEUGEOT 508 (8D_), 508 SW (8E_, 8U_)



WARNING

Health risk!

Inhalation of brake dusts may result in serious damage to the respiratory organs!

Do not clean brake components with compressed air.

Use brake cleaner fluid.

NOTE

Disconnect the battery prior to any work on the brake system.

The illustrations of these installation instructions are exemplary and are only intended for better understanding.

General reference notes

The parking brake switch is located in the dashboard. **(1)**
(see figure 1)

Figure 1

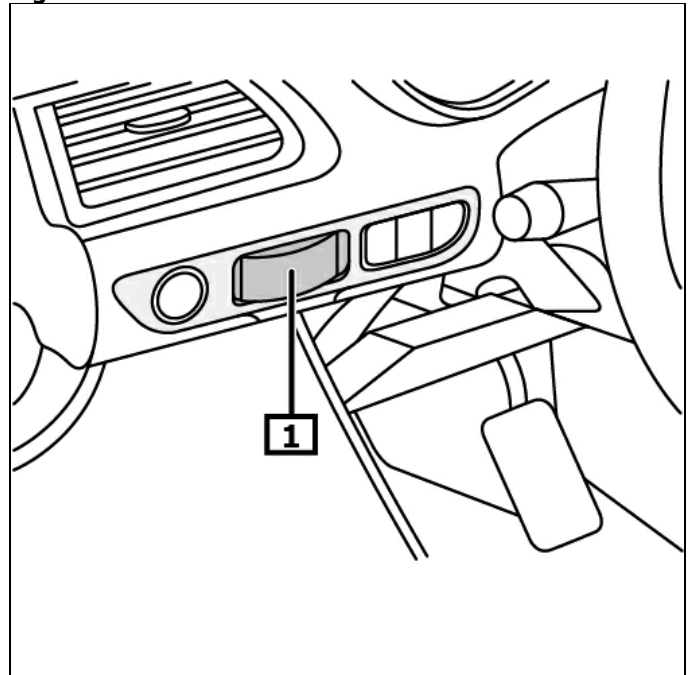

1 Parking brake switch

Display/operation

Automatic mode

The parking brake is automatically actuated after the engine has been cut with the vehicle being stationary.
The parking brake releases automatically as soon as the vehicle is being driven in the 1st gear or when reversing.

Engage parking brake

Pull parking brake switch.

Disengage parking brake

Pull parking brake switch and simultaneously apply accelerator pedal or brake pedal.

The indicator light indicates the deactivated automatic mode.

(2)

(see figure 2)

For further details and information, please refer to the operating manual!

Disconnect the battery prior to any work on the brake system.

Disengage parking brake

Disconnect battery.

After repair work

Carry out basic adjustments using suitable diagnostic unit.

Note position of EOBD connection.

Connect diagnostic unit to diagnostic connection.

Follow the instructions of the diagnostic unit.

Check fault memory, and delete fault if necessary.

Figure 2

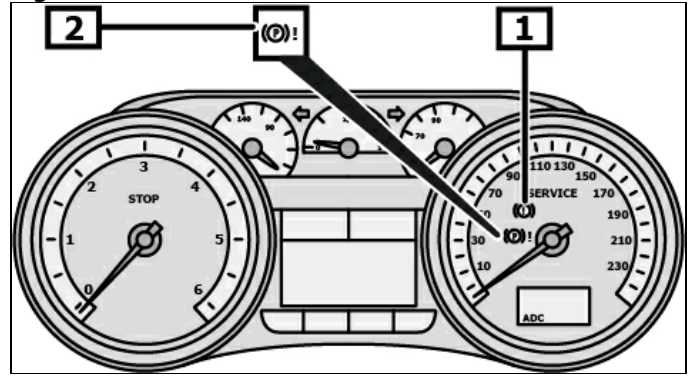

1 Indicator light

2 Indicator light

Parking brake emergency unlocking device

Carefully remove gearshift lever cover(s) using a lever and place over gearshift knob. **(1)**
Disconnect plug. **(2)**
(see figure 3)

Figure 3

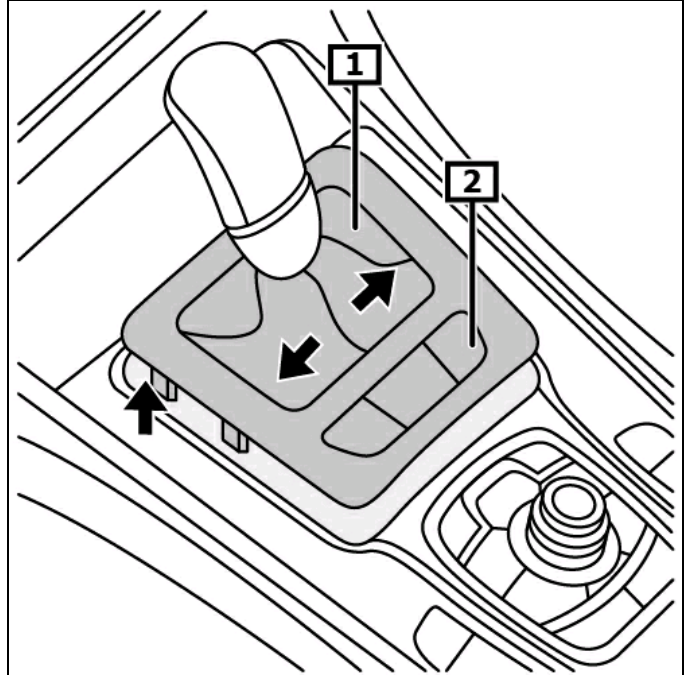

1 Cover

2 Plug

Operate release. **(1)(2)**
(see figure 4)

Figure 4

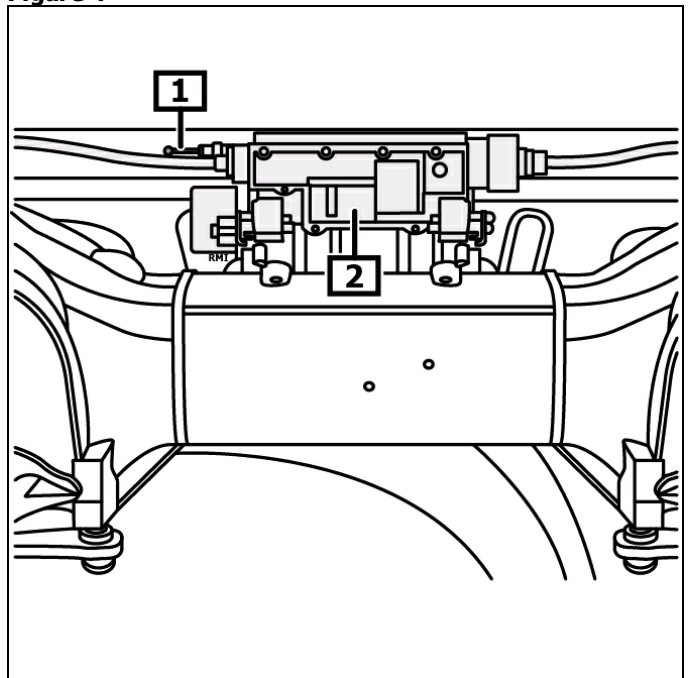

1 Release

2 Electromechanical parking brake servomotor