



OPEL ZAFIRA TOURER C (P12), VAUXHALL ZAFIRA Mk III (P12)



**WARNING**

**Health risk!**

**Inhalation of brake dusts may result in serious damage to the respiratory organs!**

**Do not clean brake components with compressed air.**

**Use brake cleaner fluid.**

**General reference notes**

The control unit with the parking brake servomotor is located under the wheel arch liner, rear left.

The switch for the parking brake is located in the center console.

**(1)**

**(see figure 1)**

**Figure 1**

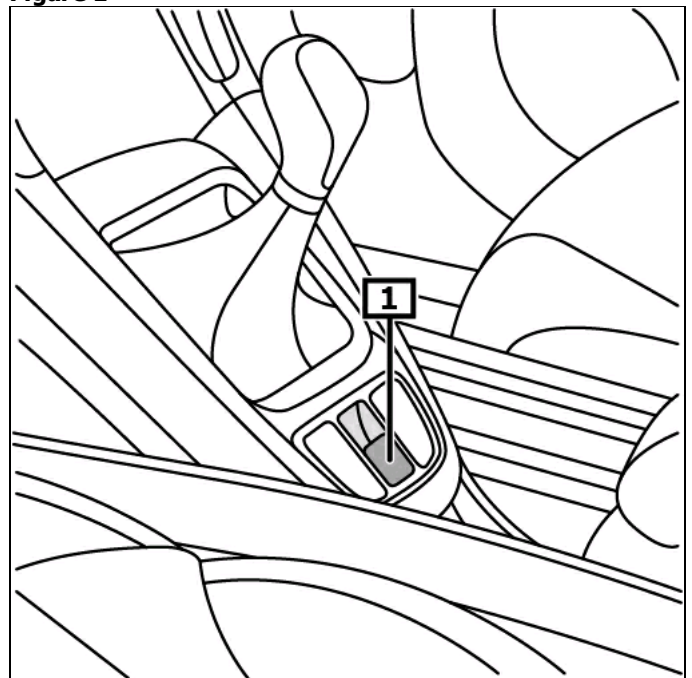

**1 Parking brake switch**

## **Display/operation**

### **Engage parking brake**

*Pull parking brake switch.*

### **Disengage parking brake**

*Switch on ignition.*

*Press parking brake switch and simultaneously operate brake pedal.*

The yellow indicator light goes on when errors occur that impair operating or traffic safety.

Read off error code on display. **(3)**

**(see figure 2)**

**For further details and information, please refer to the operating manual!**

**Figure 2**

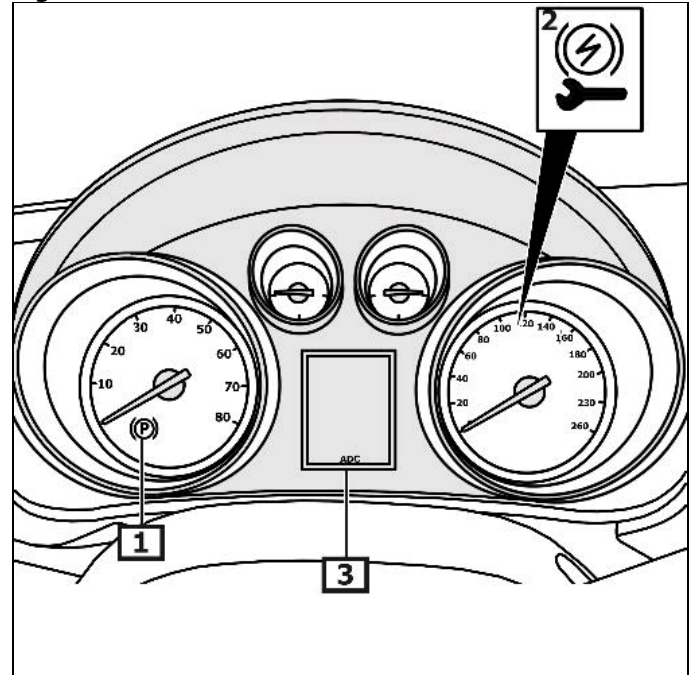

**1 Indicator light**

**2 Fault indicator light**

**3 Instrument cluster display**

## **Enable service mode**

**Activate parking brake service mode before performing any work on the parking braking system**

### **Diagnostic unit**

Secure vehicle against rolling away.  
Connect diagnostic unit to diagnostic connection.

**Note position of EOBD connection.**

Switch on ignition.

**Follow the instructions of the diagnostic unit.**

### **Manual**

Secure vehicle against rolling away.  
Switch on ignition.

### **Automatic gearbox**

Set selector lever to position "P".

### **manual gearbox**

Bring gear into neutral position.

### **Continuation for all vehicles**

Operate the brake pedal and keep it actuated.  
Depress parking brake switch and keep it depressed for approx. 5 s.  
Release switch when parking brake indicator light lights up.  
Press parking brake switch.  
Release parking brake switch.  
Release brake pedal.

## **Disable service mode**

### **After repair work**

**Carry out parking brake basic adjustment.**

### **Diagnostic unit**

Secure vehicle against rolling away.  
Connect diagnostic unit to diagnostic connection.

**Note position of EOBD connection.**

Switch on ignition.

Establish basic adjustment.

**Follow the instructions of the diagnostic unit.**

### **Manual**

Secure vehicle against rolling away.  
Switch on ignition.  
Operate the brake pedal and keep it actuated.

### **Automatic gearbox**

Set selector lever to position "P".

### **manual gearbox**

Bring gear into neutral position.

### **Continuation for all vehicles**

Pull parking brake switch.  
Release parking brake switch.  
Press parking brake switch.  
Release parking brake switch.

**Repeat procedure four times.**

**Adjustment procedure is finished.**

## **Parking brake emergency unlocking device**

### **Lift vehicle.**

Remove the wheel arch liner rear left.

Remove the rubber plugs. **(1)**

Turn screw clockwise using an appropriate tool until the handbrake cable tension is completely removed. **(2) (arrow)**  
**(see figure 3)**

**Figure 3**

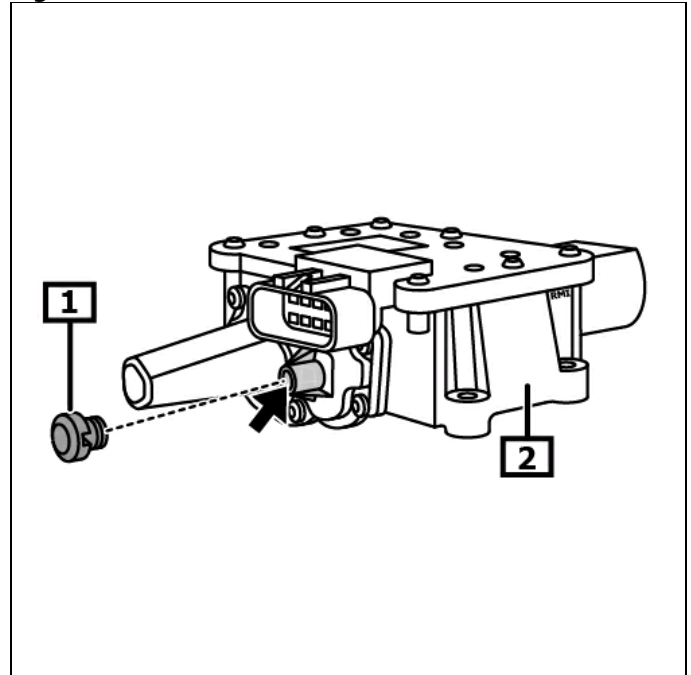

**1 Rubber stopper**

**2 Electromechanical parking brake servomotor**