



HYUNDAI i40 (VF), i40 CW (VF)



WARNING

Health risk!

Inhalation of brake dusts may result in serious damage to the respiratory organs!

Do not clean brake components with compressed air.

Use brake cleaner fluid.

NOTE

Move back brake piston using the diagnostic unit prior to any work on the brake system.

The illustrations of these installation instructions are exemplary and are only intended for better understanding.

General reference notes

The parking brake servomotors are located at the rear brake calipers.

The switch for the parking brake is located in the center console.

(1)
(see figure 1)

Figure 1

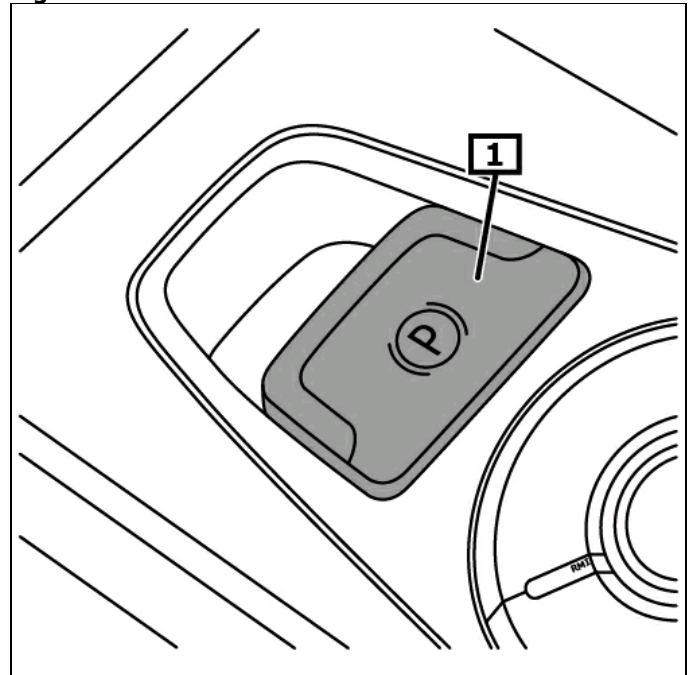

1 Parking brake switch

Display/operation

Engage parking brake

Pull parking brake switch. **(1)**

Disengage parking brake

Press parking brake switch and simultaneously operate brake pedal. **(1)**

(see figure 1)

The parking brake releases automatically as soon as the vehicle is being driven in the 1st gear or when reversing.

Attention! The electromechanical parking brake can be actuated with the ignition switched off but it cannot be released.

The red warning light goes on when errors occur that greatly impair operating or traffic safety. **(1)**

If the indicator light remains lit, or lights up while driving, an error is present. **(2)**

(see figure 2)

For further details and information, please refer to the operating manual!

Figure 2

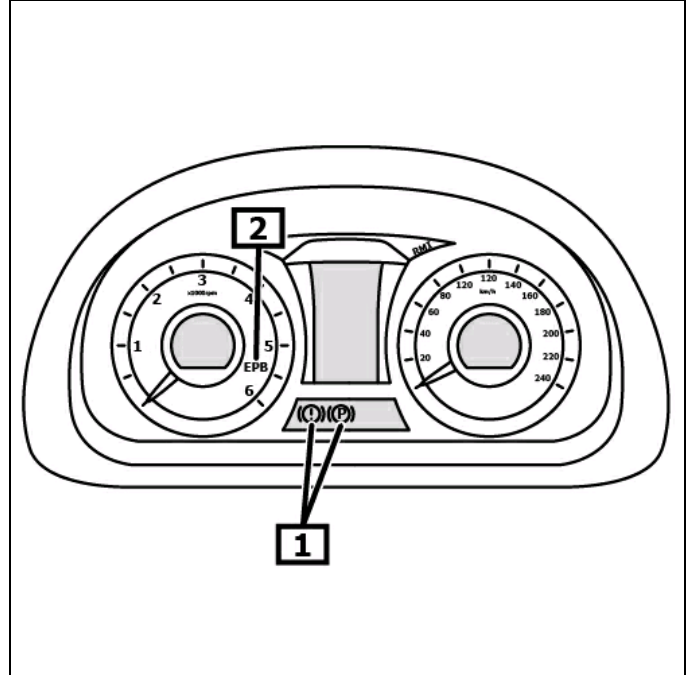

1 Electromechanical parking brake 2 Brake system warning light indicator light

Move back brake piston using a diagnostic unit prior to any work on the brake system.

Note position of EOBD connection.

Connect diagnostic unit to diagnostic connection.
Switch on ignition.
Disengage parking brake

Follow the instructions of the diagnostic unit.

After repair work

Follow the instructions of the diagnostic unit.

Carry out basic adjustments using suitable diagnostic unit.
Check fault memory, and delete fault if necessary.

Parking brake emergency unlocking device

Lift vehicle.

Remove rear wheels.
Disconnect the electric plug connection(s) on the servomotor.

Unscrew screw(s). (1)

Carefully remove servomotor from brake caliper. (2)

Turn back spindle clockwise until wheel can be turned freely. (3)
(see figure 3)

Installation in reverse order of removal.

Check brake disk(s) for free movement.

Carry out parking brake basic adjustment.

Figure 3

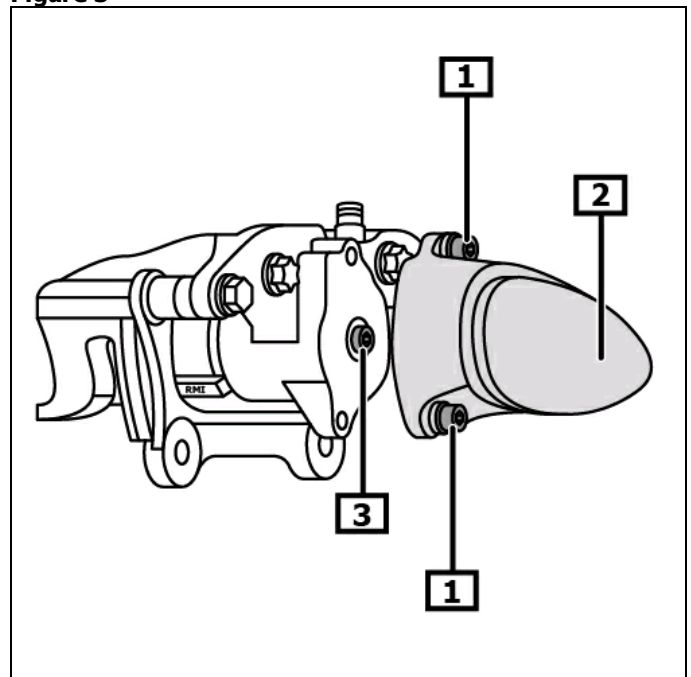

1 Screw(s)

2 Parking brake servomotor

3 Spindle