



Renault Modus, Grand Modus (F/JP0_)



DANGER

Airbag unit can trigger unintentionally!

Airbag unit is a pyrotechnic component that can lead to death on improper handling!

Only specially trained employees may carry out any work on the airbag system.

Disconnect the battery.

Always store airbag unit with the padded side pointing upward.

Always transport airbag unit in appropriate packaging.

Never leave airbag unit unattended, but lock safely in an appropriate cabinet.

Do not open or repair airbag unit.

Only install airbag unit in undamaged condition.

Do not perform any measurements on the airbag unit using a test lamp or multimeter.

Wear protective gloves and safety goggles.

No person may stay inside the vehicle when re-connecting the battery.

NOTE

Ensure proper cleanliness when working on the servo-steering.

Steering column adjustment must remain locked during steering column removal.

Generally replace self-locking as well as corroded screws and nuts.

Repair work of any kind on the electromechanical steering column is not permissible, it must basically be completely replaced.

Observe disposal regulations!

Replace steering column if the driver airbag had been triggered.

Do not use oils, fats, chemicals and cleaners not approved by the manufacturer on airbag units.

The illustrations of these installation instructions are exemplary and are only intended for better understanding.

Required special tools

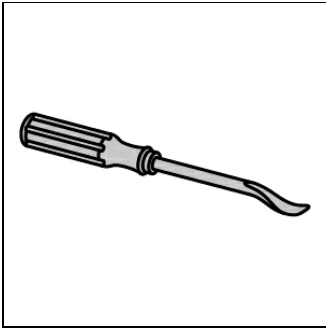

Assembly lever
OE (Car. 1597)

Required torques

Tightening torques

Self-locking screws and nuts must always be replaced.

| | | | |
|---|-----------------------|-------------------------------------|---------------------------------|
| Universal joint bolt(s) (2) | (see figure 6) | Use new screw(s) and nut(s). | 24 Nm |
| Intermediate steering shaft screw(s) (3) | (see figure 6) | Use new screw(s). | at steering column 32 Nm |
| Steering column nut(s) (1) | (see figure 7) | | 21 Nm |
| Steering wheel screw | | Use new screw(s). | 44 Nm |

Remove:

Deactivate airbag system.

Note position of EOBD connection.

Turn the steering wheel to the central position.

Disconnect battery (negative terminal).

Keep waiting time of min. 10 s.

Remove driver's airbag.

Disconnect driver's airbag electric plug connection(s).
Demount steering wheel.

Remove the fuse box cover. **(1)**

Remove switch cover. **(2)**

Disconnect electric connectors.

Remove dashboard cover(s) bottom. **(3)**

(see figure 1)

Figure 1

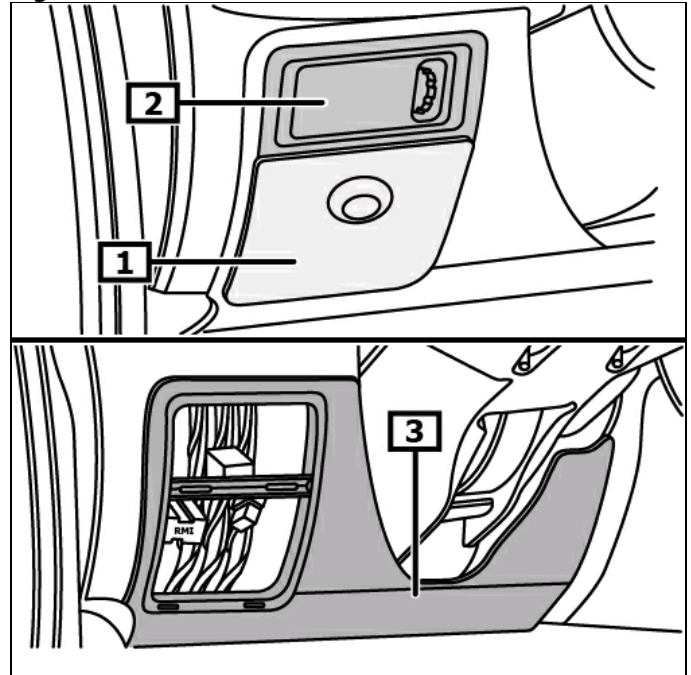

1 Fuse box cover

2 Switch cover

3 Dashboard cover(s) bottom

Unscrew and remove steering column shroud(s) lower screw(s).

(1)

Release the retaining clamp(s). **(2)**

Remove lower steering column shroud. **(3)**

Separate upper steering column shroud from flexible covering of steering column.

Remove upper steering column shroud. **(4)**

(see figure 2)

Figure 2

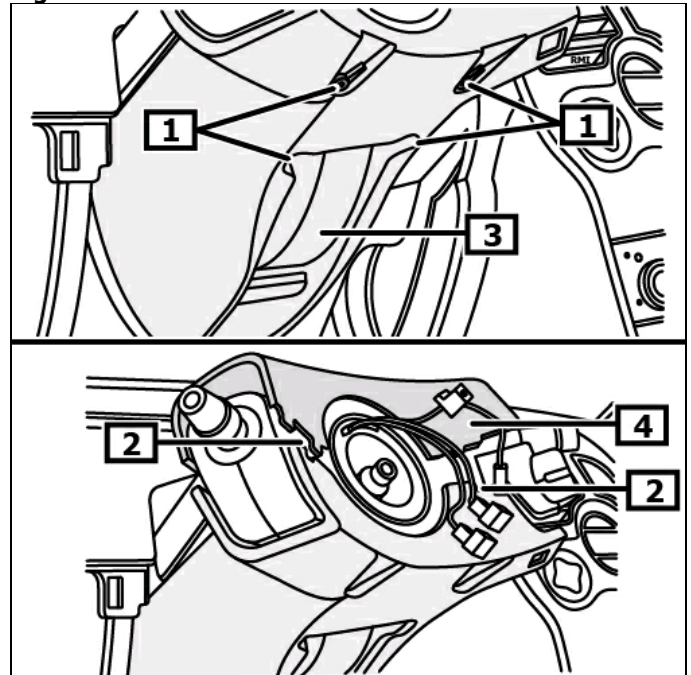

1 Steering column shroud(s) lower screw(s)

2 Retaining Clamps

3 Lower steering column shroud

4 Upper steering column shroud

Marking on contact unit must align with reference edge.

(1)

Loosen steering column module clamping collar(s). **(2)**

Remove steering column module incl. steering-column switch.

(3)

Disconnect electric connectors.

(see figure 3)

Figure 3

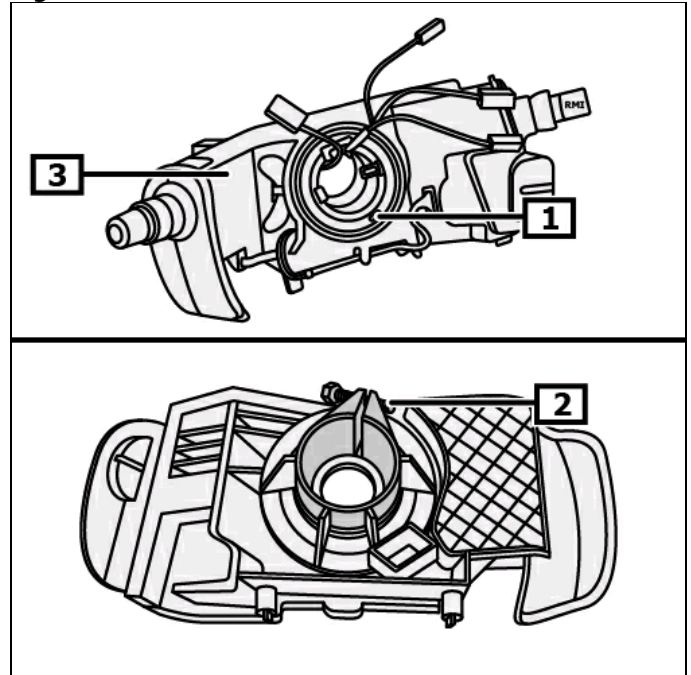

1 Mark(s)

2 Clamp(s)

3 Steering column module

Disconnect immobilizer reading coil electric plug connection. **(1)**

Loosen immobilizer reading coil lock. **(2)**

Demount read coil of immobilizer. **(3)**

(see figure 4)

Figure 4

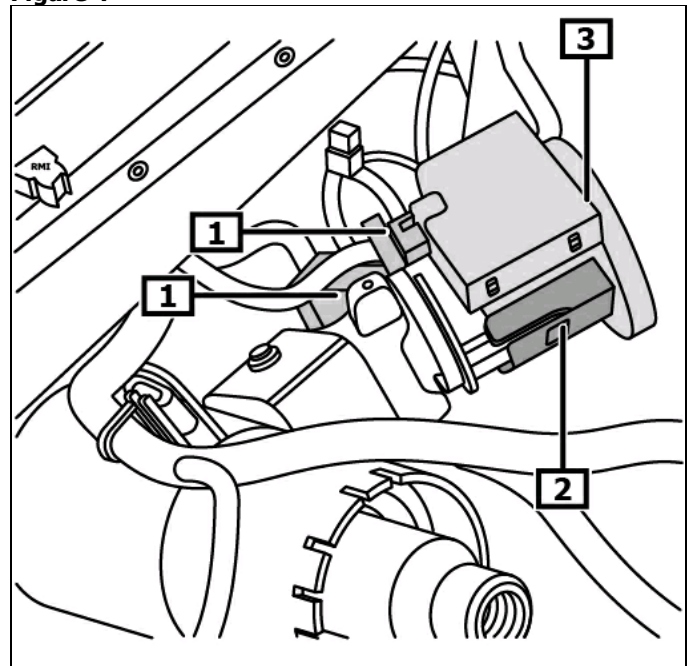

1 Immobilizer reading coil electric

2 Immobilizer reading coil lock plug connection

3 Immobilizer reading coil

Remove storage box. **(1)**
Use assembly lever.

Required special tools
Assembly lever **OE (Car. 1597)**

Disconnect steering column electric plug connection(s). **(2)**
(see figure 5)

Figure 5

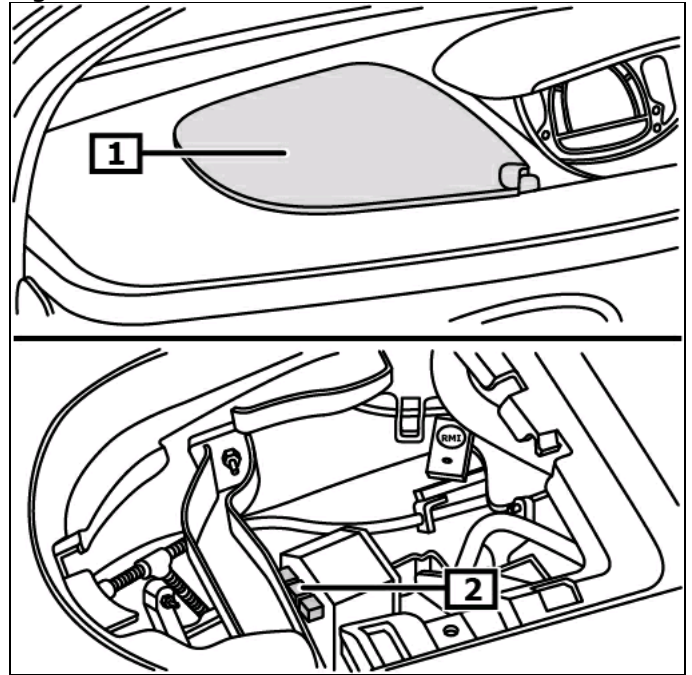

1 Parcel tray

2 Electric plug connection(s)

Fold back footwell covering, driver side.

Remove support ring. **(1)**
Unscrew universal joint bolt(s). **(2)**

Observe installation position!

Remove the universal joint upward from the steering gear.
Unscrew and remove intermediate steering shaft screw(s). **(3)**
Remove intermediate steering shaft. **(4)**
(see figure 6)

Figure 6

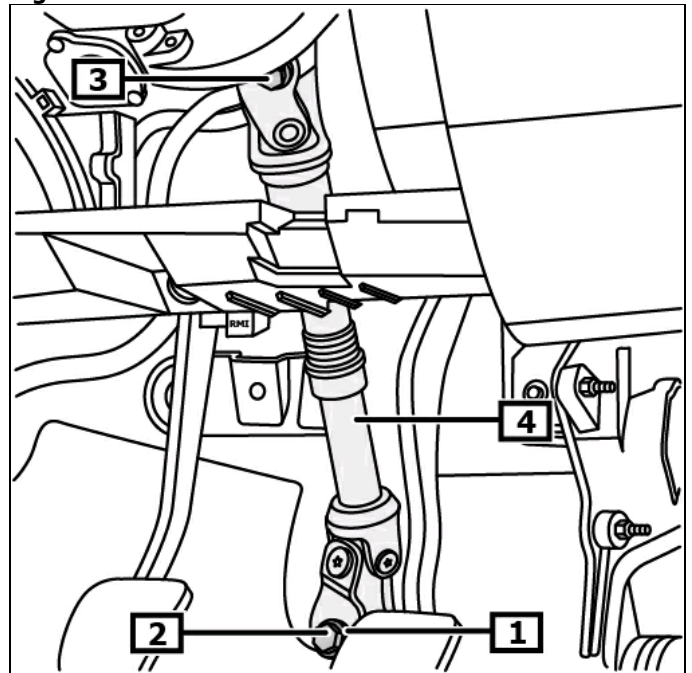

1 Supporting ring

2 Universal joint bolt(s)

3 Intermediate steering shaft

4 Intermediate steering shaft screw(s)

Unscrew and remove steering column nut(s). **(1)**
Disconnect steering column electric plug connection(s).
(see figure 7)

Convert following components when replacing the steering column:

- Ignition lock
- Intermediate steering shaft

Figure 7

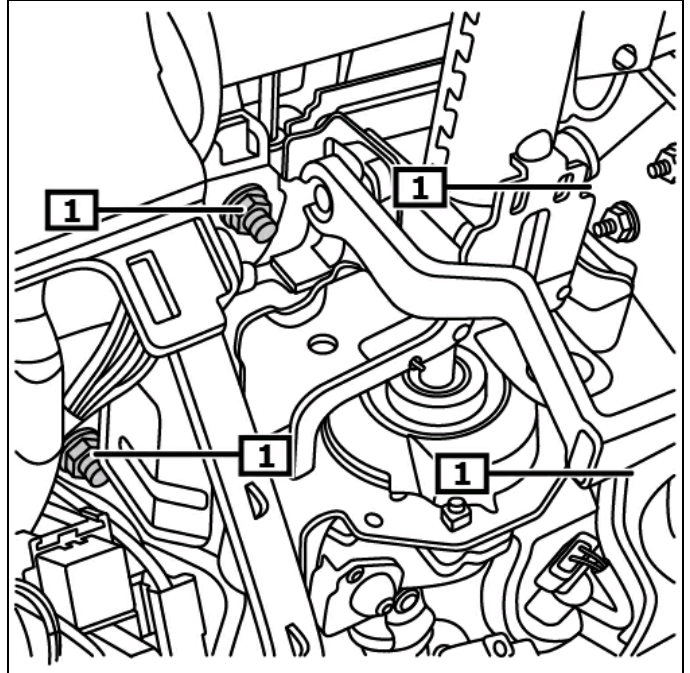

1 Steering column nut(s)

Install:

Fasten steering column using fasteners on the dashboard carrier. **(1)**
(see figure 8)

Tighten steering column nut(s). **(1)**
(see figure 7)

Continue assembly in reverse order of removal.

Figure 8

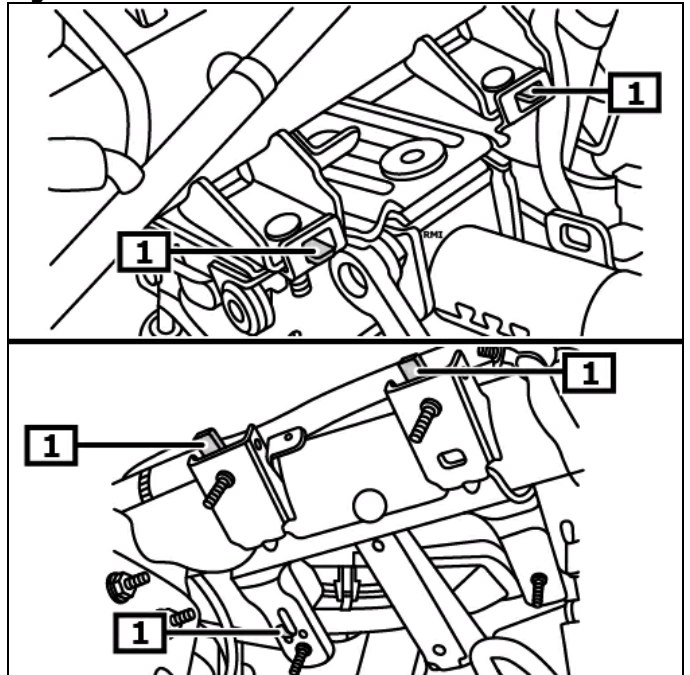

1 Attachment

Make sure that the universal joint screw is seated centered in the steering spindle recess! (1) - (4) (see figure 9)

Continue assembly in reverse order of removal.

Code radio and reprogram vehicle settings if required.
Check electrical system for function.

Teach the steering angle sensor.

Teach steering angle sensor using appropriate diagnostic unit.

Note position of EOBD connection.

Figure 9

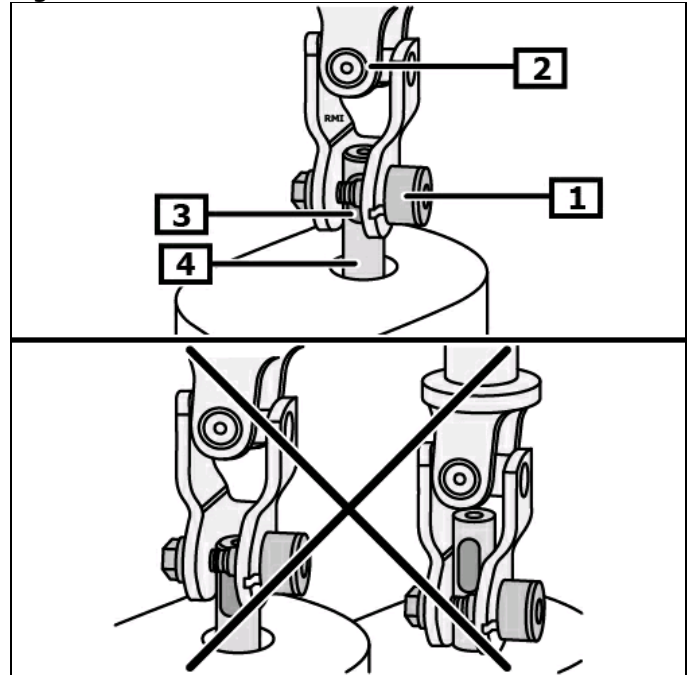

1 Universal joint bolt(s)

2 Steering gear universal joint

3 Recess

4 Steering spindle