



Renault Megane II



DANGER

Airbag unit can trigger unintentionally!

Airbag unit is a pyrotechnic component that can lead to death on improper handling!

Only specially trained employees may carry out any work on the airbag system.

Disconnect the battery.

Always store airbag unit with the padded side pointing upward.

Always transport airbag unit in appropriate packaging.

Never leave airbag unit unattended, but lock safely in an appropriate cabinet.

Do not open or repair airbag unit.

Only install airbag unit in undamaged condition.

Do not perform any measurements on the airbag unit using a test lamp or multimeter.

Wear protective gloves and safety goggles.

No person may stay inside the vehicle when re-connecting the battery.

NOTE

Ensure proper cleanliness when working on the servo-steering.

Steering column adjustment must remain locked during steering column removal.

Generally replace self-locking as well as corroded screws and nuts.

Repair work of any kind on the electromechanical steering column is not permissible, it must basically be completely replaced.

Observe disposal regulations!

Do not use oils, fats, chemicals and cleaners not approved by the manufacturer on airbag units.

The illustrations of these installation instructions are exemplary and are only intended for better understanding.

Torques

Tightening torques

Self-locking screws and nuts must always be replaced.

Screw(s) from electronic steering column lock control unit (1)	(see Figure 4)		Left-hand thread 8 Nm
Universal joint bolt(s) (2)	(see Figure 7)	Use new screw(s) and nut(s).	44 Nm
Steering wheel screw			44 Nm
Intermediate steering shaft screw(s)			at steering column 44 Nm

Remove:

Deactivate airbag system.

Note position of EOBD connection.

Turn the steering wheel to the central position.

Disconnect battery (negative terminal).

Keep waiting time of min. 10 s.

- Remove dashboard cover(s) bottom. **(1)**
 - Remove cover(s) at side of dashboard. **(2)**
 - Unscrew and remove dashboard covering screw(s). **(3)**
 - Remove dashboard covering. **(4)**
 - Disconnect electric connectors.
- (see Figure 1)**

Figure 1

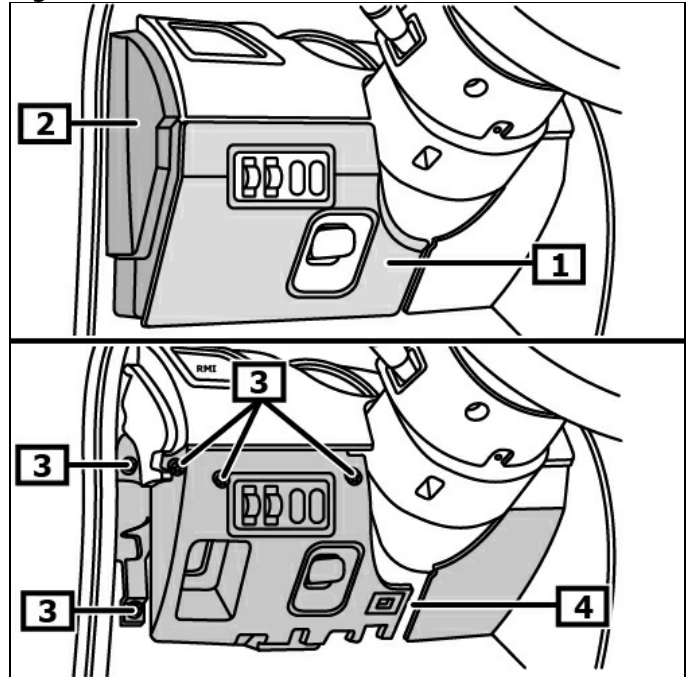

- | | |
|-------------------------------|----------------------------------|
| 1 Dashboard cover(s) bottom | 2 Cover(s) at side of dashboard. |
| 3 Dashboard covering screw(s) | 4 Dashboard covering |

Remove driver's side footwell air duct.

Remove driver's airbag.

Disconnect driver's airbag electric plug connection(s).
Demount steering wheel.

Unscrew and remove steering column shroud(s) lower screw(s).

- Remove lower steering column shroud. **(1)**
 - Release the retaining clamp(s). **(2)**
 - Remove upper steering column shroud. **(3)**
 - Marking on contact unit must align with reference edge.** **(4)**
 - Unscrew and remove steering column module screw(s). **(5)**
 - Remove steering column module incl. steering-column switch. **(6)**
 - Disconnect electric connectors.
- (see Figure 2)**

Figure 2

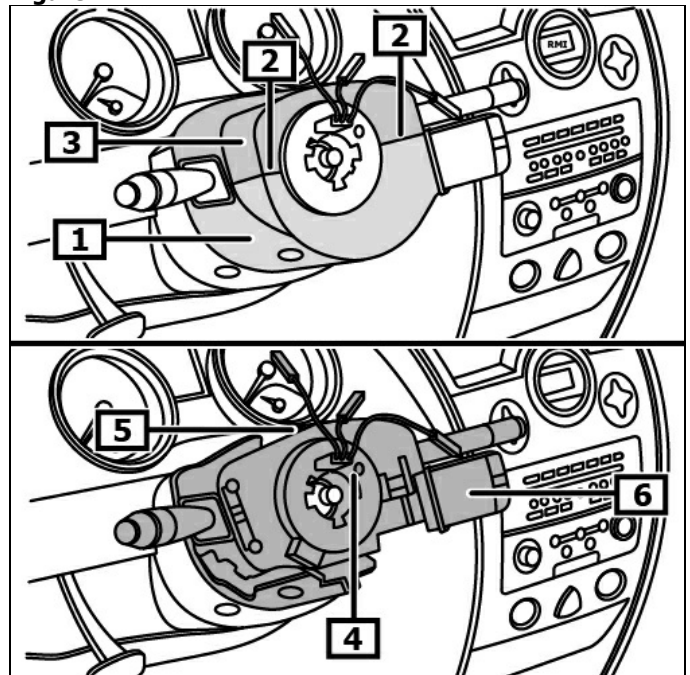

- | | |
|-----------------------------------|--------------------------|
| 1 Lower steering column shroud | 2 Retaining Clamps |
| 3 Upper steering column shroud | 4 Mark(s) |
| 5 Steering column module screw(s) | 6 Steering column module |

Remove instrument cluster cover frame. **(1)**
 Disconnect navigation system loudspeakers electric plug connection. **(If present)**
 Unscrew and remove instrument cluster screw(s). **(2)**
 Release the retaining clamp(s). **(3)**
 Demount instrument cluster. **(4)**
 Disconnect electric connectors.
(see Figure 3)

Figure 3

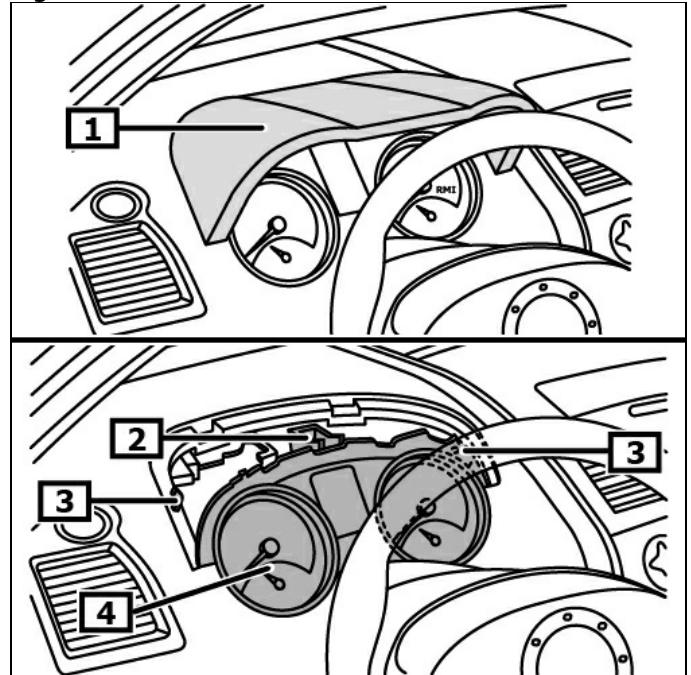

- | | |
|----------------------------------|-------------------------------|
| 1 Instrument cluster cover frame | 2 Instrument cluster screw(s) |
| 3 Retaining Clamps | 4 Instrument cluster |

Fold back footwell covering, driver side.

Remove support ring. **(1)**
 Unscrew universal joint bolt(s). **(2)**
Observe installation position!
 Remove the universal joint upward from the steering gear. **(3)**
(see Figure 4)

Disconnect steering column electric plug connection(s).
 Loosen electric cable(s) from steering column.

Unscrew and remove rear steering column nuts between
 intermediate steering shaft and brake pedal. **(4)(5)**
(see Figure 4)

Figure 4

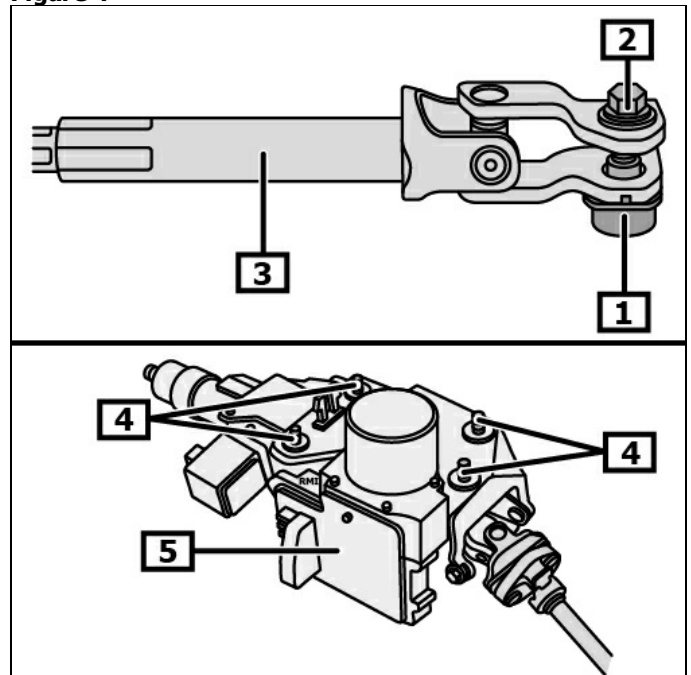

- | | |
|-------------------------------|---------------------------|
| 1 Supporting ring | 2 Universal joint bolt(s) |
| 3 Intermediate steering shaft | 4 Steering column nut(s) |
| 5 Steering column | |

Unscrew and remove screw(s) from electronic steering column lock control unit. **(1)**

The screw has a left-hand thread.

Disconnect electric connectors. **(2)**

Remove electronic steering column lock control unit. **(3)**
(see Figure 5)

Figure 5

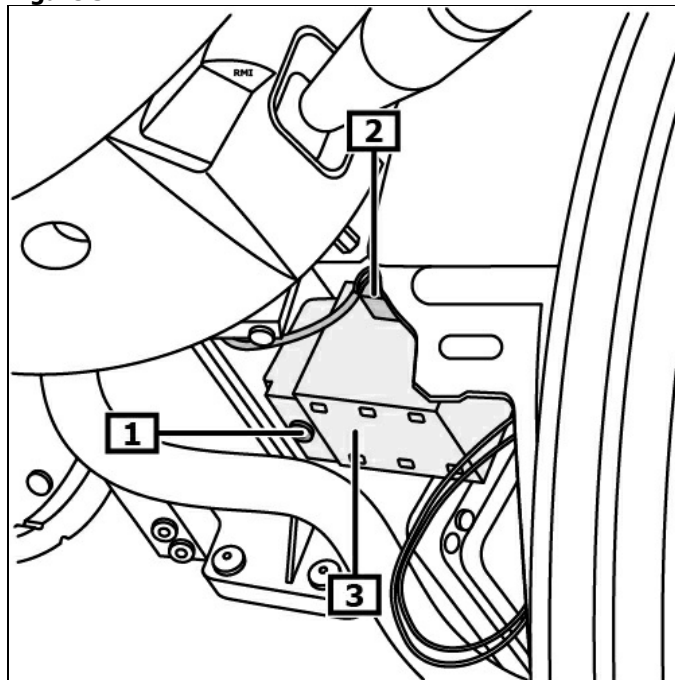

1 Screw(s) from electronic steering **2** Electrical connection(s)
column lock control unit

3 Electronic steering column lock
control unit

Unscrew and remove steering column nut(s). **(1)**
(see Figure 6)

Remove the steering column.

Figure 6

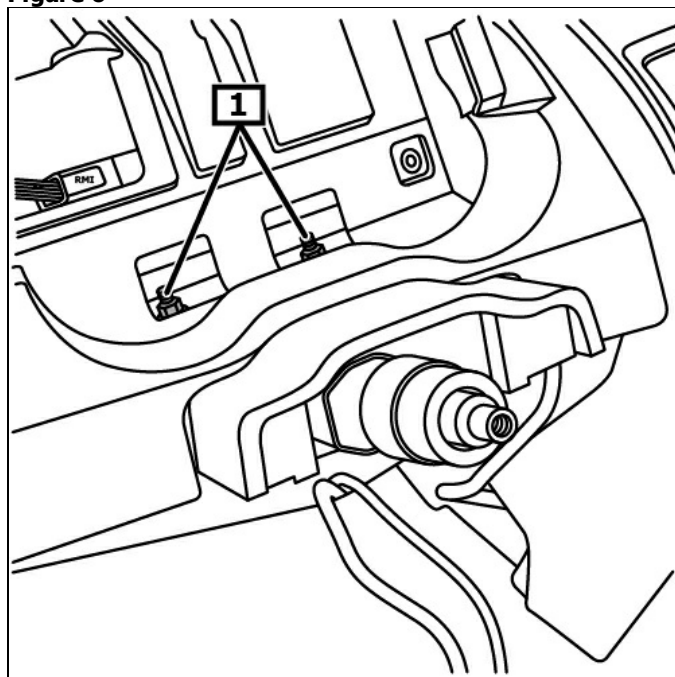

1 Steering column nut(s)

Convert following components when replacing the steering column:

- Ignition lock
- Intermediate steering shaft
- Steering column adjusting lever

Install:

Installation in reverse order of removal.

Make sure that the universal joint screw is seated centered in the steering spindle recess! (1) - (4) (see Figure 7)

Continue assembly in reverse order of removal.

Code radio and reprogram vehicle settings if required.
Check electrical system for function.

Teach the steering angle sensor.

Teach steering angle sensor using appropriate diagnostic unit.

Note position of EOBD connection.

Figure 7

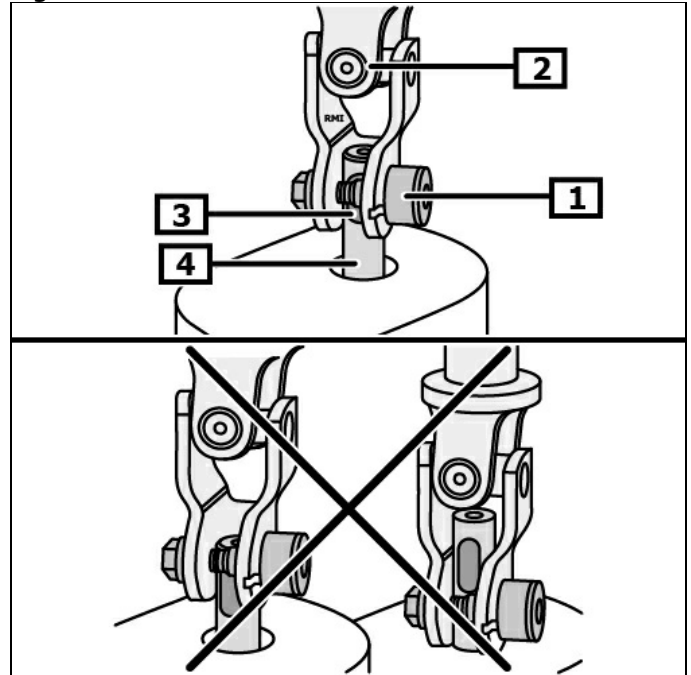

1 Universal joint bolt(s)

2 Steering gear universal joint

3 Recess

4 Steering spindle