



Vauxhall Corsa Mk III (D)



DANGER

Airbag unit can trigger unintentionally!

Airbag unit is a pyrotechnic component that can lead to death on improper handling!

Only specially trained employees may carry out any work on the airbag system.

Disconnect the battery.

Always store airbag unit with the padded side pointing upward.

Always transport airbag unit in appropriate packaging.

Never leave airbag unit unattended, but lock safely in an appropriate cabinet.

Do not open or repair airbag unit.

Only install airbag unit in undamaged condition.

Do not perform any measurements on the airbag unit using a test lamp or multimeter.

Wear protective gloves and safety goggles.

No person may stay inside the vehicle when re-connecting the battery.

NOTE

Ensure proper cleanliness when working on the servo-steering.

Steering column adjustment must remain locked during steering column removal.

Generally replace self-locking as well as corroded screws and nuts.

Repair work of any kind on the electromechanical steering column is not permissible, it must basically be completely replaced.

Observe disposal regulations!

Do not use oils, fats, chemicals and cleaners not approved by the manufacturer on airbag units.

The illustrations of these installation instructions are exemplary and are only intended for better understanding.

Required special tools

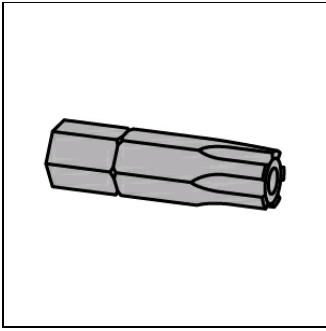

Bit socket
OE (CH-48829)

Required torques

Tightening torques

Self-locking screws and nuts must always be replaced.

Steering column module screw(s) (3)	(see figure 3)		20 Nm
Universal joint bolt(s) (1)	(see figure 5)	Clean the thread and use screw-locking compound.	top 40 Nm; bottom 55 Nm
Steering column screw(s). (2)	(see figure 6)	Note correct order of tensioning.	22 Nm
Steering spindle screw(s) (1)	(see figure 7)	Use new screw.	at steering column 24 Nm + 60°
Steering wheel nut(s)			30 Nm

Remove:

Move steering wheel to the centre position and let steering lock engage.

Disconnect battery (negative terminal).

Keep waiting time of min. 1 min.

Remove driver's airbag.

Demount steering wheel.

Unscrew and remove steering column shroud(s) screw(s). **(1)**
Remove steering column panel(s). **(2)**
Detach electric line from lower steering column shroud. **(see figure 1)**

Figure 1

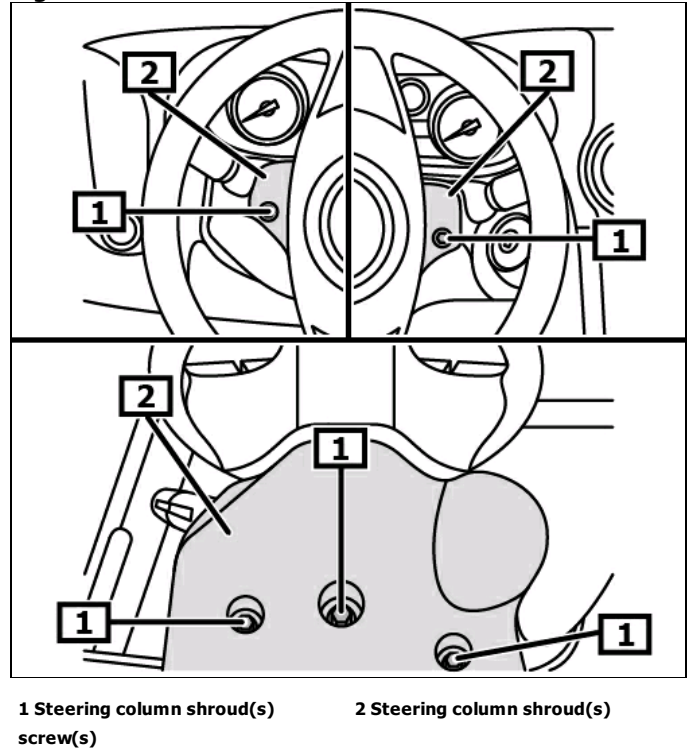

Disconnect cruise control system electric plug connection(s). **(If present) (1)**

Unlock steering column switch engagement pin using suitable tool. **(2)**

Remove direction indicator steering column switch. **(3)**

Unlock steering column switch engagement pin using suitable tool. **(2)**

Remove windscreen wiper steering column switch. **(4)**

(see figure 2)

Figure 2

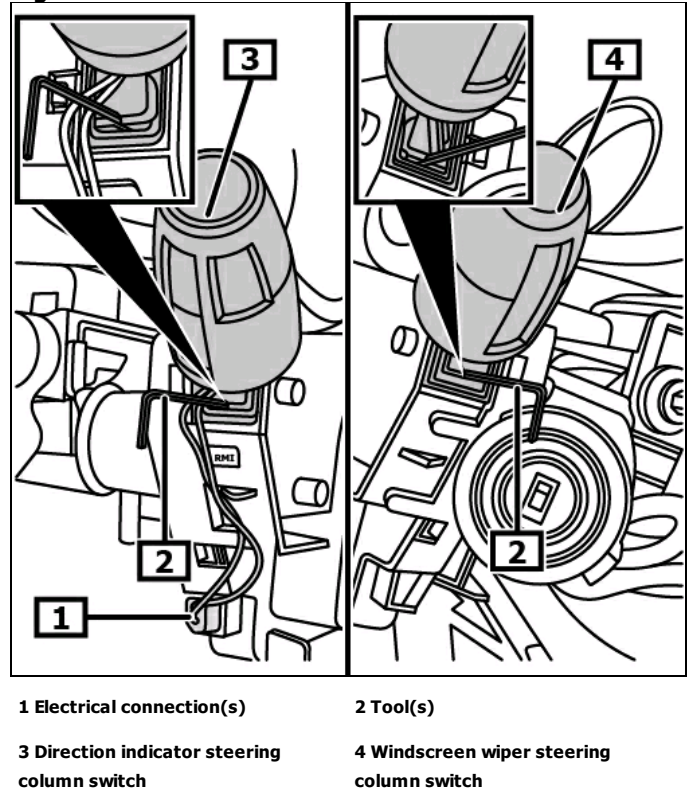

Disconnect steering column module electric plug connection(s). **(1)(2)**
 Unscrew and remove steering column module screw(s). **(3)**

Required special tools
 Bit socket **OE (CH-48829)**

Loosen steering column module retaining device. **(4)**
 Turn the ignition key to the 1 position.
 Remove steering column module. **(5)**
(see figure 3)

Figure 3

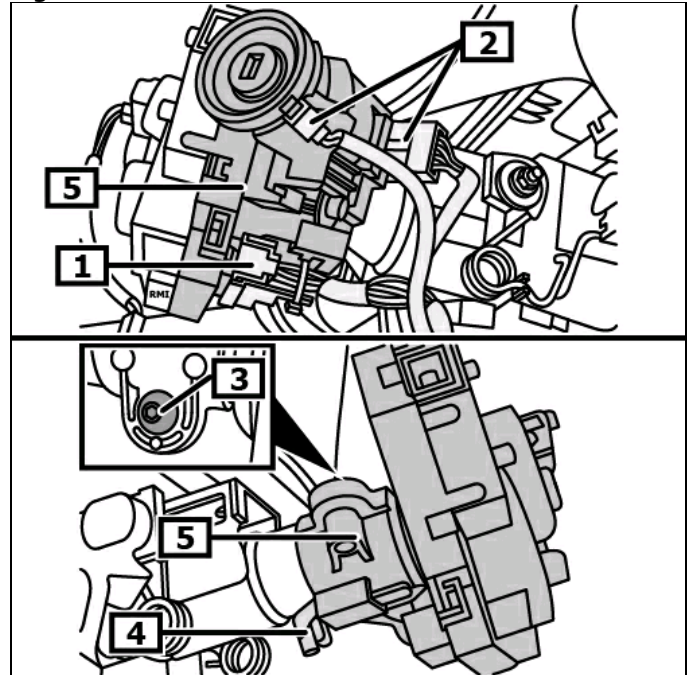

- 1 Electrical connection(s)
- 2 Electrical connection(s)
- 3 Steering column module screw(s)
- 4 Steering column module retaining device
- 5 Steering column module

Remove driver's side footwell air duct.
 Open fuse box cover.

Unscrew and remove driver's side footwell paneling screw(s). **(1)**
 Remove the footwell paneling. **(2)**
(see figure 4)

Figure 4

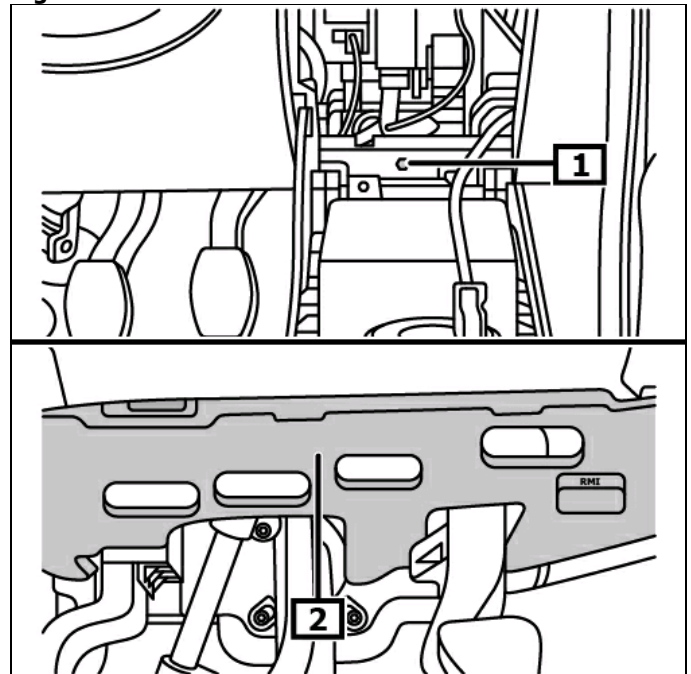

- 1 Driver's side footwell paneling
- 2 Footwell paneling screw(s)

Unscrew universal joint bolt(s). **(1)**
Remove the universal joint upward from the steering gear. **(2)**
(see figure 5)

Figure 5

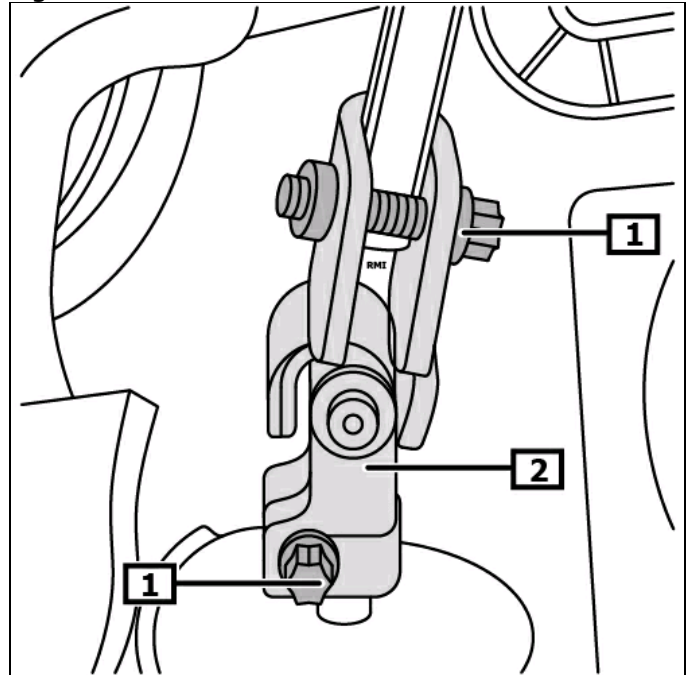

1 Universal joint bolt(s)

2 Steering universal joint

Remove electric plug connection from electric power steering control unit. **(1)**
Unscrew the steering column screw(s). **(2)**
(see figure 6)

Remove the steering column.

Figure 6

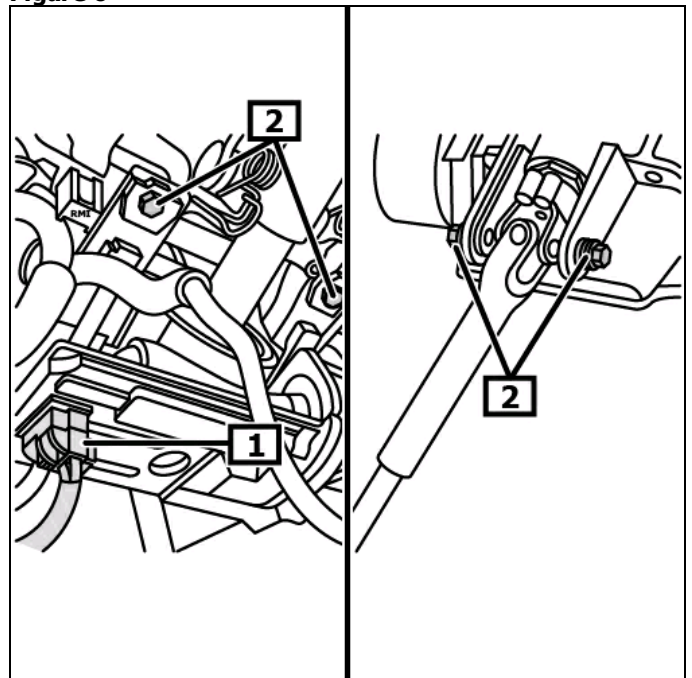

1 Electrical connection(s)

2 Steering column screw(s).

Unscrew and remove steering spindle screw(s). **(1)**
Remove steering spindle from steering column. **(2)**
(see figure 7)

Install:

Steering column tilt adjustment must be locked!

Installation in reverse order of removal.

Tighten steering column screw(s) in following tightening order.
(2)

Tighten screws in the order lower left, lower right, upper left,
upper right.

(see figure 6)

Continue assembly in reverse order of removal.

Code radio and reprogram vehicle settings if required.
Check electrical system for function.

Teach the steering angle sensor.

Check driving position to the front, adjust if needed.
(maximum deviation 5°)

Switch on ignition.
Turn the steering wheel up to the right and left stop.
Power steering indicator light goes out.

Steering-angle sensor needs to be teached-in using a suitable
diagnostic unit if power steering indicator light does not go out.

Note position of EOBD connection.

Figure 7

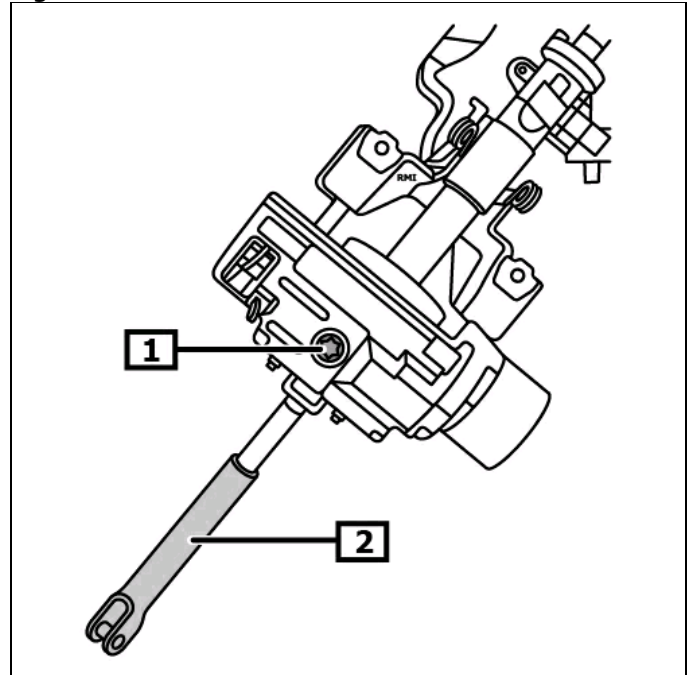

1 Steering spindle screw(s)

2 Steering spindle